

● Performance curve

ISO9906 Annex A 2900rpm

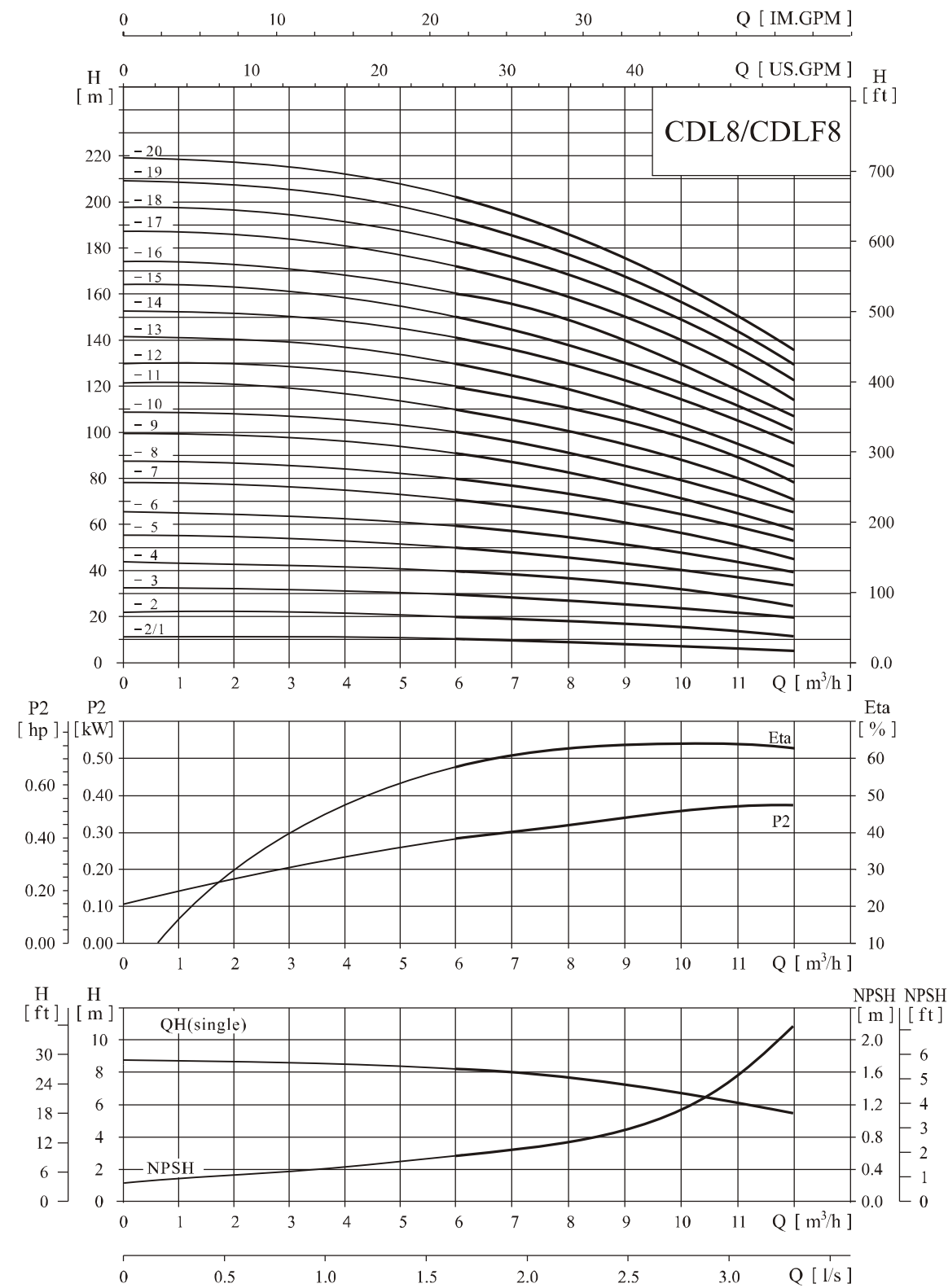

● Performance table

Model	Driving motor		Q (m³/h)	5	6	7	8	9	10	11	12
	(kW)	(hp)									
CDL8-2/1	0.75	1	H (m)	10	9.5	9.3	9	8.5	8	7	6
CDL8-2	0.75	1		20	19.5	19	18	17	16	14	13
CDL8-3	1.1	1.5		30	29.5	28.5	27	25	24	21	19
CDL8-4	1.5	2		41	39.5	38	36	34	32	28	26
CDL8-5	2.2	3		52	50	48	45	42	40	36	32
CDL8-6	2.2	3		62	60	57	54	51	48	43	39
CDL8-8	3.0	4		83	80	77	73	69	65	58	52
CDL8-10	4.0	5.5		104	100	97	92	87	81	73	65
CDL8-12	4.0	5.5		124	120	116	111	104	92	87	78
CDL8-14	5.5	7.5		145	141	136	130	122	113	102	92
CDL8-16	5.5	7.5		166	161	156	148	139	130	118	106
CDL8-18	7.5	10		187	182	175	167	157	146	134	120
CDL8-20	7.5	10		208	202	195	186	175	163	150	135

● Installation sketch

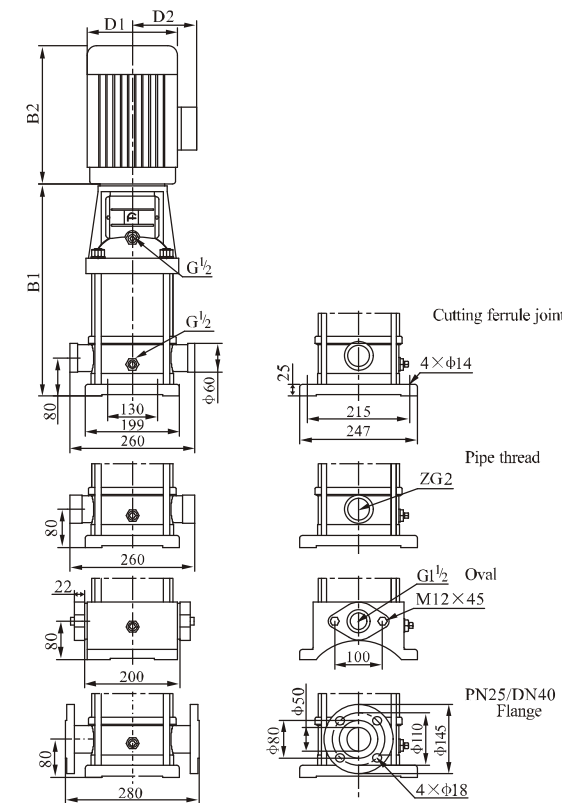

CDL8-14 ~ 8-20 sub-connection of pipeline has no oval flange
The overall dimensions of the single-phase motor and explosion-proof motor are a little different. Pls contact us for details.

● Size and weight

Model	Size (mm)					Weight (kg)
	B1	B2	B1+B2	D1	D2	
CDL8-2/1	347	245	592	170	142	22
CDL8-2	347	245	592	170	142	22
CDL8-3	377	245	622	170	142	32
CDL8-4	417	290	707	190	155	32
CDL8-5	447	290	737	190	155	42
CDL8-6	477	290	767	190	155	42
CDL8-8	547	315	862	197	165	47
CDL8-10	607	335	942	230	188	57
CDL8-12	667	335	1002	230	188	57
CDL8-14	747	430	1177	260	208	82
CDL8-16	807	430	1237	260	208	82
CDL8-18	867	430	1297	260	208	92
CDL8-20	927	430	1357	260	208	92